

IRE-3.0 IR Emitter with Visible LED

INSTALLATION INSTRUCTIONS



ELT03300

LIT03300 02/02

DESCRIPTION

The IRE-3.0 represents the highest level in sophistication for attachable IR Emitters. It features a unique EZ-Docker™ port that permits instant removal of the emitter when rearranging or servicing components. It flashes visible red when emitting IR control signals. It has 75% lower IR output than non-visible emitters and therefore should be used when controlling multi-zone components to avoid cross-zone interaction. An improved adhesive reduces callbacks for reattachment of “fallen emitters”.

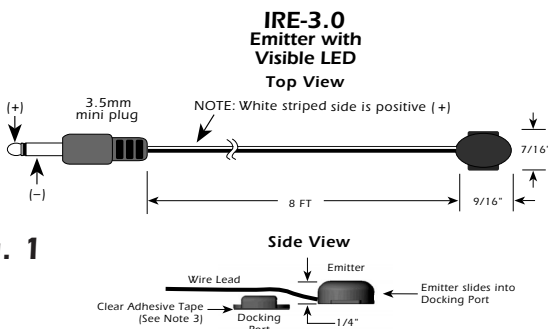

Fig. 1

ATTACHMENT

First, locate the component's IR Sensor window (See Note 1) and thoroughly clean it of any fingerprints or other greasy substances. The EZ-Docker™ port has a clear adhesive layer on its bottom surface. Peel the protective layer off, exposing the adhesive.

Orient the port vertical (see Fig. 2) and press it over the center of the component's sensor window. Press & hold for several seconds to ensure maximum contact of the adhesive.

Slide the emitter from the top down, into the EZ-Docker™ port. You should feel it “snap” into place.

IR Controlled Components

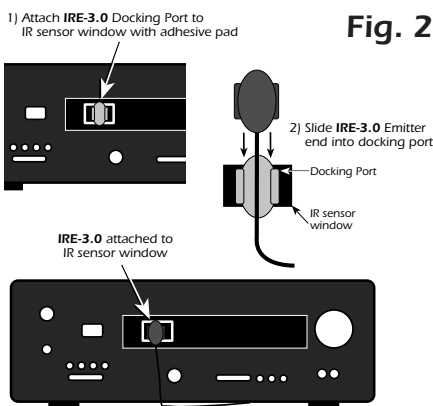

Fig. 2

(To remove the emitter at any time, simply push upward until it “pops” out).

Insert the 3.5mm plug into an Emitter jack on a SpeakerCraft Terminator or other source of IR (see Fig. 3).

CAUTION: Do not plug into an emitter jack that is set to Blaster Power (BL ON) or to the HIGH OUT of other connecting blocks. **To do so will smoke the emitters!!**

Note 1: If you have difficulty finding the component's IR sensor, try using a flashlight. Sometimes the owner's manual is helpful. You may need to contact the manufacturer direct.

Note 2: You may also attach the emitter without the EZ-Docker™ port. Use one of the spare adhesives (included) applying it directly to the bottom surface of the IRE-3.0 shell.

Note 3: If you need to remove the EZ-Docker™ port or emitter previously stuck to a component's surface, use a fresh adhesive (included) before reattaching.

TYPICAL INSTALLATION

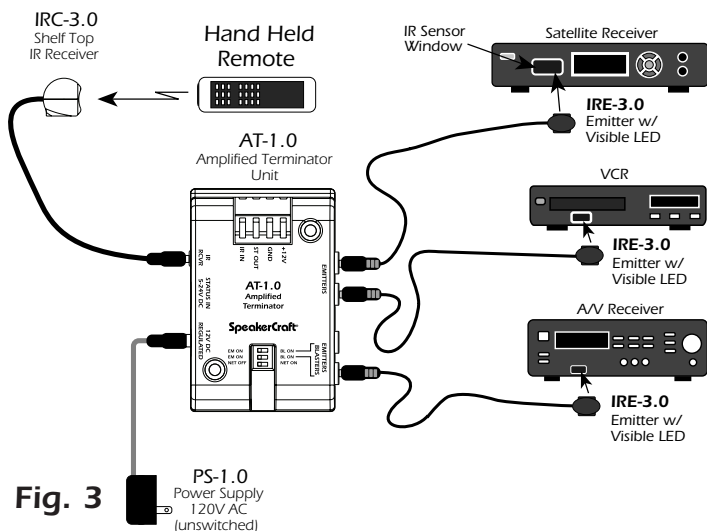

Fig. 3

Note 4: The emitter shell and EZ-Docker™ port, though dark in appearance, are transparent to Infrared. This allows IR commands to pass through them, permitting local hand held remote control as well as through the IRE-3.0.

LIMITED 5-YEAR WARRANTY

SpeakerCraft warrants this product to be free of defects in materials or workmanship. This extends for five years from the date of purchase by the original consumer. Any products returned to SpeakerCraft and found to be defective by SpeakerCraft within the warranty period will be repaired or replaced, at SpeakerCraft's option, at no charge. SpeakerCraft will not be responsible for the actual cost of installation or removal of the product, nor for any incidental or consequential damages. Some states do not allow the exclusion or limitation of incidental or consequential damages, so the above limitation may not apply to you. This warranty gives you specific legal rights. You may have additional legal rights that vary from state to state.